

# Technical Specifications

## DECTRIS EIGER<sup>®</sup>2 X 500K-RW

*Document Version v1.8.1*

**DECTRIS Ltd.**

5405 Baden-Daettwil  
Switzerland  
[www.dectris.com](http://www.dectris.com)



# CONTENT

<b>CONTENT</b>	<b>i</b>
<b>DOCUMENT HISTORY</b>	<b>iii</b>
Current Document . . . . .	iii
Changes . . . . .	iii
<b>1 GENERAL INFORMATION</b>	<b>1</b>
1.1 Contact and Support . . . . .	1
1.2 Explanation of Symbols . . . . .	1
1.3 Warranty Information . . . . .	2
1.4 Disclaimer . . . . .	2
<b>2 USE OF THE EIGER2 X 500K-RW</b>	<b>3</b>
2.1 Product Return and Recycling . . . . .	3
<b>3 TECHNICAL SPECIFICATIONS</b>	<b>4</b>
3.1 Specifications . . . . .	4
3.1.1 Detector . . . . .	4
3.2 Ratings . . . . .	5
3.2.1 Detector . . . . .	5
3.2.2 Power Supply Unit . . . . .	5
3.2.3 Detector Control Unit . . . . .	6
3.2.4 Thermal Stabilization Unit . . . . .	6
3.3 Ambient Conditions . . . . .	7
<b>4 DETECTOR DIMENSIONS AND CONNECTORS</b>	<b>8</b>
4.1 EIGER2 X 500K-RW Detector . . . . .	8
4.1.1 Technical Drawing . . . . .	8
4.1.2 Front Side of the Detector . . . . .	9
4.1.3 Back Side of the Detector . . . . .	10
4.1.4 Status LEDs . . . . .	11
4.1.5 Connectors and Connecting Cables/Pipes . . . . .	11
4.2 Detector Control Unit . . . . .	12
4.2.1 Configuration . . . . .	12
4.2.2 Connectors . . . . .	14
4.3 Thermal Stabilization Unit . . . . .	15
4.3.1 In-Vacuum Operation . . . . .	16
<b>5 INSTALLING THE DETECTOR SYSTEM</b>	<b>17</b>
5.1 Transport Considerations . . . . .	17
5.2 Mylar®Frame . . . . .	17
5.2.1 In-Air Operation . . . . .	17
5.2.2 In-Vacuum Operation . . . . .	17
5.3 Mounting . . . . .	19
5.3.1 Mounting from Below . . . . .	20
5.3.2 Mounting from Above . . . . .	20
5.4 Grounding of the Detector . . . . .	21
5.5 Connection to Dry Air or Nitrogen . . . . .	21
5.5.1 In-Vacuum Use . . . . .	22
5.6 Fiber Optic Cable Installation . . . . .	22
5.6.1 Installing the Cables . . . . .	22
5.6.2 Checking the Connection . . . . .	23
5.6.3 Cleaning the Connectors . . . . .	23
5.7 Connection to Thermal Stabilization Unit . . . . .	23
5.8 Mounting the Detector Control Unit . . . . .	24

<b>6</b>	<b>TEMPERATURE AND HUMIDITY CONTROL</b>	<b>25</b>
<b>7</b>	<b>OPERATION PROCEDURE</b>	<b>26</b>
7.1	Getting Started . . . . .	26
7.2	Startup Procedure . . . . .	26
7.3	Turning Off the Detector . . . . .	26
7.4	Vacuum Operation . . . . .	27
7.4.1	Ambient Conditions for In-Vacuum Use . . . . .	27
7.4.2	Operation Procedure In-Vacuum . . . . .	27
7.5	Storing the Detector . . . . .	28
7.6	Cleaning and Maintenance . . . . .	28
<b>8</b>	<b>TROUBLESHOOTING</b>	<b>29</b>

## DOCUMENT HISTORY

### Current Document

**Table 1:** Current Version of this Document

Version	Date	Status	Prepared	Checked	Released
v1.8.1	2023-02-09	release	DanM, MaMe	MaMu, MaxB	DanM

### Changes

**Table 2:** Changes to this Document

Version	Date	Changes
v1.0.0	2017-04-09	First release.
v1.2.0	2017-09-04	EIGER2 R 500K integration.
v1.3.2	2017-09-04	PILATUS3 and EIGER2 R 500K API documentation integration.
v1.4.0	2018-06-19	EIGER2 Si detector series integration
v1.5.0	2020-03-02	New layout and rework of the technical specifications.
v1.5.1	2020-06-08	Fixed EIGER2 16M image of ground plate.
v1.6.0	2020-09-08	EIGER2 CdTe detector series integration.
v1.6.1	2020-11-27	EIGER2 S series integration.
v1.6.2	2021-01-14	EIGER2 XE 9M & 16M integration.
v1.7.0	2021-09-06	Introduced trademarks and general rework.
v1.7.1	2021-10-20	Update technical drawings.
v1.7.2	2022-02-24	Improve instructions on water cooling and cable handling.
v1.7.3	2022-02-24	Add manual for EIGER2 9M-V-RW.
v1.7.4	2022-04-14	Fixed EIGER2 vacuum operation and updated trademarks.
v1.8.0	2022-03-22	Documenting new features from release 2022.1
v1.8.1	2023-02-10	Updated frame rates and 8 bit mode for X and XE systems.

## 1. GENERAL INFORMATION

### 1.1. Contact and Support





Address: DECTRIS Ltd.  
Taefernweg 1  
5405 Baden-Daettwil  
Switzerland

Phone: +41 56 500 21 02  
Fax: +41 56 500 21 01

Homepage: <http://www.dectris.com/>  
Email: [support@dectris.com](mailto:support@dectris.com)

Should you have questions concerning the system or its use, please contact us via telephone, mail or fax.

### 1.2. Explanation of Symbols

<b>Danger</b>	<b>#0</b>
	<b>Danger blocks are used to indicate immediate danger or risk to personnel or equipment.</b>
Warning	#0
	Warning blocks are used to indicate danger or risk to personnel or equipment.
Caution	#0
	Caution blocks are used to indicate danger or risk to equipment.
Information	#0
	Information blocks are used to highlight important information.

### 1.3. Warranty Information

Caution

#1



Do not ship the system back before you receive the necessary transport and shipping information.

---

### 1.4. Disclaimer

DECTRIS® has carefully compiled the contents of this manual according to the current state of knowledge. Damage and warranty claims arising from missing or incorrect data are excluded.

DECTRIS® bears no responsibility or liability for damage of any kind, also for indirect or consequential damage resulting from the use of this system.

DECTRIS® is the sole owner of all user rights related to the contents of the manual (in particular information, images or materials), unless otherwise indicated. Without the written permission of DECTRIS® it is prohibited to integrate the protected contents in this publication into other programs or other websites or to use them by any other means.

DECTRIS® reserves the right, at its own discretion and without liability or prior notice, to modify and/or discontinue this publication in whole or in part at any time, and is not obliged to update the contents of the manual.

## 2. USE OF THE EIGER2 X 500K-RW

The EIGER2 X 500K-RW hybrid-photon-counting (HPC) detector system has been designed for the detection of X-rays produced by synchrotrons or laboratory sources. It is intended for indoor use only. For other applications, please contact DECTRIS® technical support for additional information.

Caution

#2



Improper use of the DECTRIS® detector system can compromise its safety and its functionality is no longer guaranteed.

Caution

#3



When using the detector in vacuum strictly follow the in-vacuum instructions given in this document.

### 2.1. Product Return and Recycling

We recycle DECTRIS® detector systems that are no longer suitable for use. If you are not using your DECTRIS® detector system any more, send it back to us. We will make sure that your system is responsibly and safely recycled. This is free for customers who purchased a new DECTRIS® detector system.



## 3. TECHNICAL SPECIFICATIONS

### 3.1. Specifications

#### 3.1.1. Detector

**Table 3.1:** Technical Specifications

Detector technology	Hybrid Photon Counting (HPC)
Number of modules (W x H)	1 x 1 = 1
Sensor material	Silicon (Si)
Sensor thickness	450 $\mu\text{m}$
Pixel size (W x H)	75 $\mu\text{m}$ x 75 $\mu\text{m}$ = 5625 $\mu\text{m}^2$
Pixel array format (W x H)	1028 pixel x 512 pixel = 526 336 pixel
Active area (W x H)	77.1 mm x 38.4 mm = 2977.99 $\text{mm}^2$
Defective pixels	< 0.05%
Image bit depth	32, 16 or 8 bit
Readout bit depth	16 or 8 bit
Maximum count rate	$1.7 \times 10^9$ photons/s/ $\text{mm}^2$
Adjustable threshold range	3.5 keV to 30 keV
Energy range	6 keV to 40 keV
Number of thresholds	two independent thresholds
Readout time	continuous readout with 100 ns dead time
Maximum frame rate (continuous) <sup>1</sup>	4500 Hz (8 bit), 2250 Hz (16 bit)
Point-spread function	1 pixel (FWHM)
Connection to detector control unit	2 x LC/UPC duplex fiber optic connectors
Power supply	External power supply unit
Software interface	HTTP REST interface (via network connection)
Dimensions (W x H x D)	114 mm x 92 mm x 241.5 mm
Weight	3.7 kg
Overvoltage category	II
Means of protection	I (power supply)
Pollution degree	II
Maximum operating altitude	2000 m a.s.l.

<sup>1</sup> Single threshold. Using two thresholds halves the frame rate.



## 3.2. Ratings

### 3.2.1. Detector

**Table 3.2:** Power Ratings

Detector power input	+12 V DC, 60 W
Detector external trigger input	High level: 2.1 – 5.0 V Low level: 0.0 – 0.8 V
<div style="background-color: #ffff00; padding: 5px; display: flex; justify-content: space-between;"> <span>Caution</span> <span>#4</span> </div> <div style="margin-top: 5px;">  Absolute maximum is 5V. Applying a higher voltage will damage the detector.         </div>	
External trigger input impedance	47 kΩ
Detector trigger output	High level: 2.3 V to 3.3 V Low level: 0.0 V to 0.6 V Max. current: 24 mA

### 3.2.2. Power Supply Unit

Information	#1
 Please consult the user documentation of the Mean Well GST160A12 power supply unit for details.	
<div style="background-color: #ffff00; padding: 5px; display: flex; justify-content: space-between;"> <span>Caution</span> <span>#5</span> </div> <div style="margin-top: 5px;">  Only use the power supply delivered with the EIGER2 X 500K-RW.         </div>	

**Table 3.3:** Power Supply Unit Ratings

Power supply unit power input	85 VAC to 264 VAC 47 Hz to 63 Hz 1 A to 1.85 A
Power supply unit power output	12 VDC max. 11.5 A 138 W
AC connector	IEC-320-C14 input inlet
Case dimensions (W x H x D)	72 mm x 35 mm x 175 mm
Weight	0.7 kg

### 3.2.3. Detector Control Unit

Information #2



Please consult the user documentation of the DELL PowerEdge R940 for details.

**Table 3.4:** Detector Control Unit Ratings

Detector control unit power input	2 x 100V to 240V AC, 50/60Hz, 5 A to 10 A, 750 W (Platinum) 1+1 redundant, hot swappable power supply unit
Dimensions (W x H x D)	482.4 mm x 130.3 mm x 776.46 mm
Weight	<50 kg
Chassis	3U

### 3.2.4. Thermal Stabilization Unit

Information #3



Please consult the user documentation of the SMC HEC 002-A5B thermal stabilization unit for details.

Caution #6



The maximum allowable coolant pressure is 3 bar.

**Table 3.5:** Thermal Stabilization Unit Ratings

	Value
Thermal stabilization unit power input	Single phase 100VAC to 240VAC, allowable voltage range $\pm 10\%$ , 50/60 Hz, 8 A (100 VAC) to 3 A (240 VAC)
Dimensions (W x H x D)	270 mm x 393 mm x 436 mm
Weight	17.5 kg
Typical flow	3 L min <sup>-1</sup>
Maximum operation pressure	3 bar

### 3.3. Ambient Conditions

Caution

#7



The EIGER2 X 500K-RW detector is equipped with a temperature and a humidity sensor. When either sensor detects that the operating conditions are not met, the detector will shut off. However, as the sensors may not prevent damage, temperature and humidity should be monitored to avoid breaching the operation limits.

The EIGER2 X 500K-RW detector is designed for indoor use only. The ambient conditions shown in table 3.6 must be satisfied. The stated values are for the ambient conditions.

Values inside the detector, in particular due to the dry-air or nitrogen supply, are different. These are described in section 5.5 and chapter 6.

**Table 3.6:** Detector Operating Ambient Conditions

Ambient Condition	Value
Operating temperature	+20 °C to +35 °C
Operating humidity	<80 % at 20 °C, non-condensing
Storage temperature	+15 °C to +40 °C
Storage humidity	<40 % at 20 °C, non-condensing

Caution

#8



Please consider the following points when storing the detector

- Make sure the temperature and the humidity inside the transport box does not exceed the specified range (use of a drying agent is required).
- Ensure that no condensation moisture develops if the detector is stored at low temperature.

## 4. DETECTOR DIMENSIONS AND CONNECTORS

### 4.1. EIGER2 X 500K-RW Detector

#### 4.1.1. Technical Drawing

Information

#4



3D step files of the EIGER2 X 500K-RW detector are available on request. Please contact DECTRIS® technical support for more information.

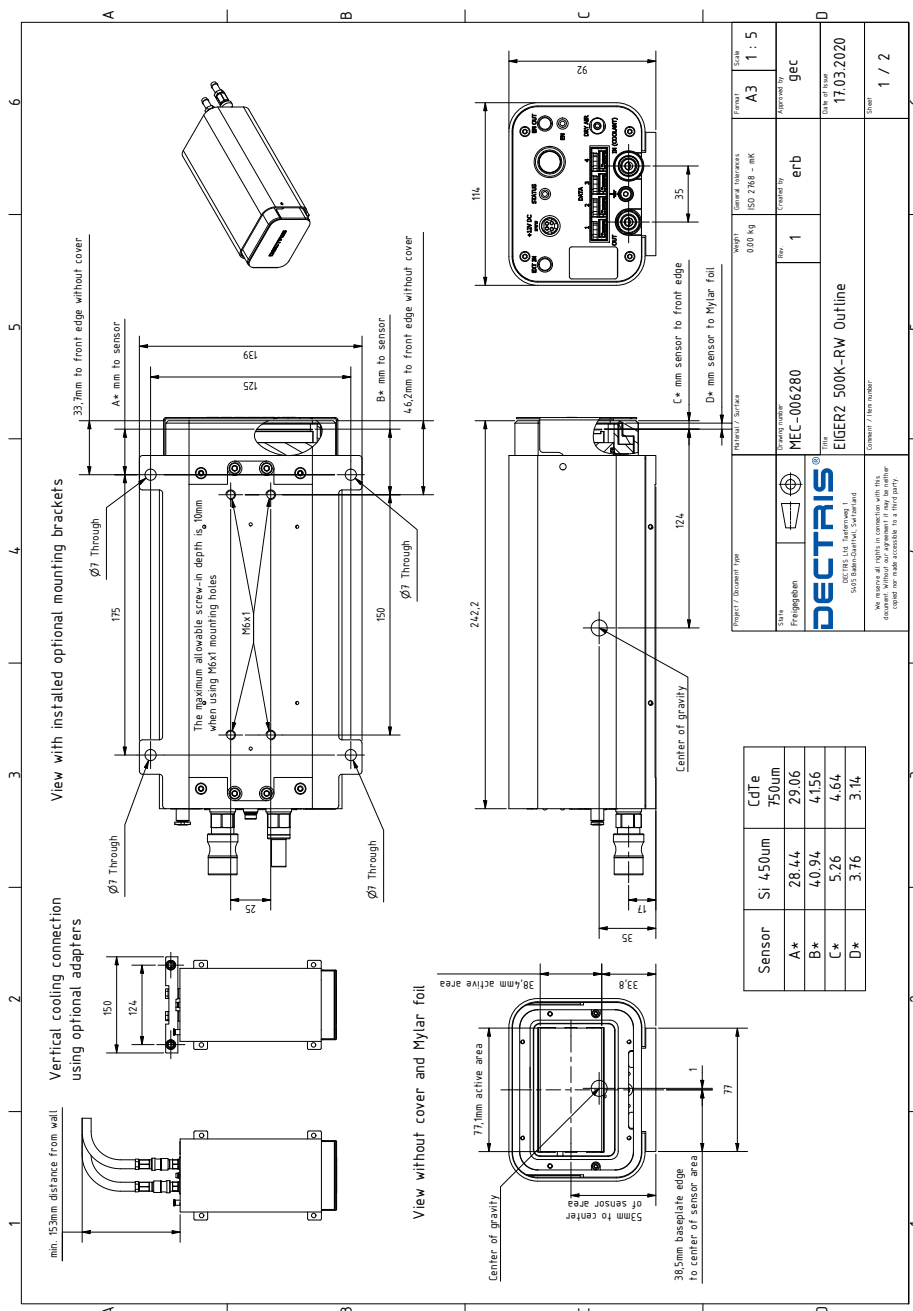

Figure 4.1: Drawing of the EIGER2 X 500K-RW Detector (also printed separately in the user documentation folder)

#### 4.1.2. Front Side of the Detector

##### Danger

#1



**Danger of electric shock. Do not touch the Mylar® foil. The sensors behind the Mylar® foil are operated at high voltages. Touching the Mylar® foil can cause an electrical shock.**

##### Warning

#1



Do not touch the Mylar® foil to avoid damage of the sensors.

##### Caution

#9



The cover may not protect the detector from a direct beam.

The detector comes with a protective cover (1.5 mm, steel) for the front window, which should only be removed during operation. The sensors are behind a 12 µm thick Mylar® (PET) foil coated with aluminum to protect them from humidity, dust and from being touched.

To remove the protective cover, the screws behind the holes at the front on both sides of the detector have to be screwed inwards. This will release the cover and the cover can be removed by pulling it up and to the front. To place the cover back on, carefully replace the cover making sure not to touch the Mylar® foil and then screw out the screws on both sides of the detector until you feel some slight resistance. Do not apply any force on the screws, the screws do not need to be tightened to hold the cover in place and excessive force can damage the housing.



**Figure 4.2:** The EIGER2 X 500K-RW Detector with the Cover Removed (front view)

### 4.1.3. Back Side of the Detector



**Figure 4.3:** The EIGER2 X 500K-RW Detector (back view)

#### 4.1.4. Status LEDs

**Table 4.1:** The Meaning of the Status LEDs on the Detector Back Plane

LED	Behavior	Description
EN	Orange	Indicates the detector is in counting mode.
STATUS	Green steady	Detector running and hardware OK.
	Green blinking	Detector hardware OK, detector in Standby or Startup mode. ⇒ Press standby button to turn on the detector.
	Red blinking	Detector may be overheating or humidity too high ⇒ Check cooling system and dry air supply
	Off	Detector has no power ⇒ Check the power adapter and mains connection.



#### 4.1.5. Connectors and Connecting Cables/Pipes

**Table 4.2:** Electric Connectors and Connecting Cables

Connector	Description
DATA	<p>2 x LC/UPC duplex fiber optic connectors DATA 1 -&gt; det1 DATA 2 -&gt; det2</p> <p>The unused data ports are closed with an EMI plug. Do not remove the plugs.</p> <p>Use Single Mode fiber optic patch cable with LC/UPC duplex connectors at both ends. We recommend to use the optic patch cables that are supplied with the detector system. Detector and detector control unit are equipped with 10GBASE-LR Single Mode SFP+ optical transceivers. Do not replace the optical transceivers, as proper function of the detector system cannot be guaranteed otherwise. Please contact support@dectris.com if you need replacement transceivers.</p> <div style="background-color: yellow; padding: 5px; margin-top: 10px;"> <p style="text-align: center;">Caution <span style="float: right;">#10</span></p> <p> There must be a 2 x LC/UPC duplex fiber optic connectors point-to-point connection between detector and detector control unit.</p> </div>
POWER	DC power connector (see tables 3.2 and 3.3)
EXT IN	External trigger input (see table 3.2) Use a Lemo® Type 00 (NIM/CAMAC) cable.
EN OUT	Enable out, high when counting is enabled. Use a Lemo® Type 00 (NIM/CAMAC) cable.



**Table 4.2:** Electric Connectors and Connecting Cables - continued

Connector	Description
	Functional ground
	<div style="background-color: #003366; color: white; padding: 5px; display: flex; justify-content: space-between;"> <span>Information</span> <span>#5</span> </div> <p> Although the detector might be already grounded via the mounting bolts, the detector should be grounded additionally via the functional ground connector at the back to establish a defined grounding.</p>

**Table 4.3:** Air Connectors

Connector	Description
DRY AIR	Dry air or nitrogen for humidity control. Use a hose/pipe with an outer diameter of 4 mm. To release the tube press and hold the blue ring before pulling at the tube.

**Table 4.4:** Coolant Connectors (see section 5.7)

Connector	Description
IN	Coolant inlet. Quick coupling dry-break double shut-off.
OUT	Coolant outlet. Plug dry-break double shut-off.
	<div style="background-color: #ffff00; padding: 5px; display: flex; justify-content: space-between;"> <span>Caution</span> <span>#11</span> </div> <p> For in-vacuum operation do not use the standard connectors. A specific vacuum feedthrough set containing all required parts is available from DECTRIS®.</p>

## 4.2. Detector Control Unit

### 4.2.1. Configuration

<span>Caution</span> <span>#12</span>
<p> Do not access or modify the operating system of the detector control unit.</p>

The user interface of the detector control unit is accessible using a web browser. The detector control unit does not need any connections other than the power and Ethernet cables.

The detector control unit has to be connected point-to-point to the detector via 2 x LC/UPC duplex fiber optic connectors. The detector control unit can be integrated into the site network infrastructure using one of the interfaces described in table 4.5. The detector control unit is optimized for performance and stability of operation. In order to achieve these goals we deliver the detector control unit with fixed firmware (BIOS etc.) and software (OS) version. The detector control unit must not be operated in an environment where unauthorized access is possible. The detector control unit does not provide authentication mechanisms and is not protected against malicious acts by unauthorized third parties.

Using the web front end, it is possible to restart the EIGER2 control service, trigger an update, and to shut down and to reboot the detector control unit. Any further control of the detector is carried out via the SIMPLON API (see separate documentation).



**Figure 4.4:** Front view of the detector control unit (not in actual configuration).

Caution

#13



Pushing the power button on the front panel longer than 2 seconds will immediately halt the detector control unit. All image data on the detector control unit will be permanently lost.

Information

#6



Briefly pushing the power button on the front panel will shut down the detector control unit. May take up to 1 min.

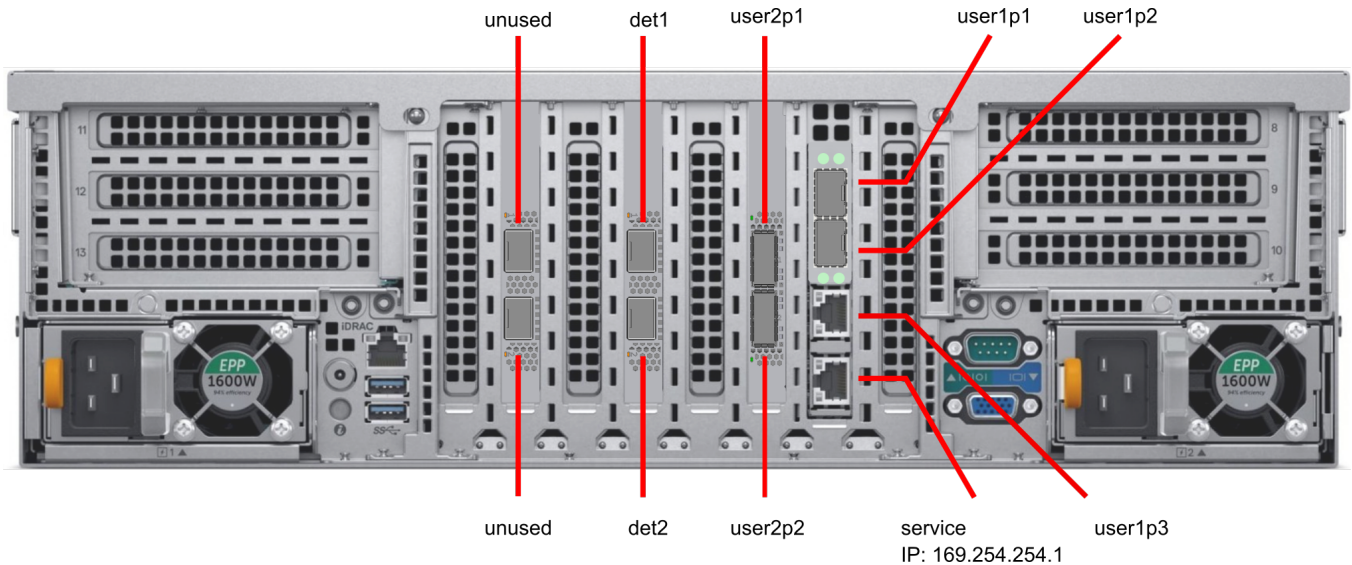

**Figure 4.5:** Back view of detector control unit with labeled network interfaces.

#### 4.2.2. Connectors

**Table 4.5:** Detector Control Unit Connectors

Connector	Description
user1p1 (Integrated NIC)	Interface name: user1p1 (10 GbE SFP+) User configurable 10 GbE network interface Preconfiguration: DHCP
user1p2 (Integrated NIC)	Interface name: user1p2 (10 GbE SFP+) User configurable 10 GbE network interface Preconfiguration: Static 10.42.41.10 (Netmask 255.255.255.0)
user1p3 (Integrated NIC)	Interface name: user1p3 (1 GBase-T) User configurable GbE network interface Preconfiguration: DHCP
service (Integrated NIC)	Interface name: service (1 GBase-T) Fallback GbE network interface Preconfiguration: Static 169.254.254.1 (Netmask 255.255.255.0)
user2p1 (Slot 3)	Interface name: user2p1 User configurable 100 Gb QSFP28 network interface
user2p2 (Slot 3)	Interface name: user2p2 User configurable 100 Gb QSFP28 network interface
DATA	Detector interface ports DATA 1 -> det1 DATA 2 -> det2 The unused data ports are closed with an EMI plug. Do not remove the plugs.
2 x Power	AC Connector (redundant power supply)

See DELL owner’s manual for further details.

### 4.3. Thermal Stabilization Unit

A thermal stabilization unit is required for the operation of the EIGER2 X 500K-RW detector system.

The hoses and the detector are equipped with self-sealing valves to avoid dripping when connecting or disconnecting the tubes.

The tubing should be kept as short as possible to ensure the best flow.

**Table 4.6:** Operating Conditions

Condition	Definition
Operating temperature	The thermal stabilization unit has to be set to a temperature of 23 °C for normal operation.
Maximum operating pressure	3 bar
Coolant	Use 66 % distilled water and 34 % ethylene glycol.

**Danger #2**

 Ethylene glycol can be seriously harmful to your health or fatal if handled incorrectly. Consider the packaging and safety instructions provided by your local supplier.

Information #7



Before operating the thermal stabilization unit, please read the User Manual of the thermal stabilization unit.

Caution #14



When connecting or disconnecting the cooling hoses, turn off the detector and the thermal stabilization unit.

Caution #15



When operating the detector, the thermal stabilization unit must always be turned on and the pump has to be activated (see user documentation of thermal stabilization unit).

Caution #16



Use opaque hoses to avoid the growth of algae.

Caution #17



Do not set the temperature of the thermal stabilization unit below the recommended operating temperature. Condensing moisture can develop and damage the detector.

### 4.3.1. In-Vacuum Operation

Vacuum compatibility can be provided as an option. For in-vacuum operation unscrew the self-sealing valves from the detector and use vacuum-compatible fittings and o-rings. The water connectors use an 1/8 inch ISO parallel thread. Before opening the cooling circuit always remove the coolant to avoid dripping.

**Table 4.7:** In-Vacuum Operating Conditions

Condition	Definition
Operating temperature	<p>Before and during pumping down and venting the thermal stabilization unit has to be set to a temperature of 23 °C for at least 30 min.</p> <p>Prior to powering up and operating the detector in-vacuum the thermal stabilization unit has to be set to a temperature of 17 °C for at least 30 min.</p>

## 5. INSTALLING THE DETECTOR SYSTEM

### 5.1. Transport Considerations

Warning

#2



Avoid vibration and shock when moving the detector.

The detector has been delivered in a robust transport box. Please keep this transport box for transport or storage purpose.

### 5.2. Mylar®Frame

Depending of the mode of operation (in-air or in-vacuum operation) the Mylar® frame can be mounted or removed:

- Mount/remove the Mylar® frame in a clean, dust-free and humidity-controlled environment. Minimize the time the sensors are exposed without protection.
- After mounting/removing of the Mylar® frame immediately attach dry air (in-air operation) or pump down the system (in-vacuum operation) to keep humidity as low as possible.

#### 5.2.1. In-Air Operation

For in-air operation the Mylar® frame has to be mounted. The detector comes with a protective cover for the front window which should be removed for operation. The sensors are behind a 12 µm thick Mylar® (PET) foil coated with aluminum to protect it from dust and touch.

#### 5.2.2. In-Vacuum Operation

**Danger**

#3



**Danger of electric shock. Do not touch the sensors. The sensors are operated at high voltages. The detector must be switched off and disconnected from power sources before mounting or removing the Mylar® frame.**

Warning

#3



Be very careful when mounting and removing the Mylar® frame and avoid touching the sensor under all circumstances, as this will most likely result in a damaged sensor. Make sure the Mylar® frame does not tilt inward through the opening at any time. Stay clear of the detector volume with any kind of object. This operation is restricted to trained personnel. Damage caused by improper handling is not covered in the warranty.

Warning

#4



Do not expose the sensors to humidity, dust or touch.

Caution

#18



The screws holding the Mylar® frame are close to the Mylar® foil, be careful that the screw driver does not slip and damage the frame.



The metal cover can also be used to protect the sensors if the Mylar<sup>®</sup> frame is not mounted.

For in-vacuum operation the Mylar<sup>®</sup> frame can be removed (figure 5.1). To unmount the Mylar<sup>®</sup> frame remove the four screws in the frame (front face) of the frame (figure 5.2). Once the Mylar<sup>®</sup> frame is removed the sensors are unprotected from humidity, dust and touch. For mechanical protection the cover can be mounted, but the sensors are still unprotected from humidity and dust.

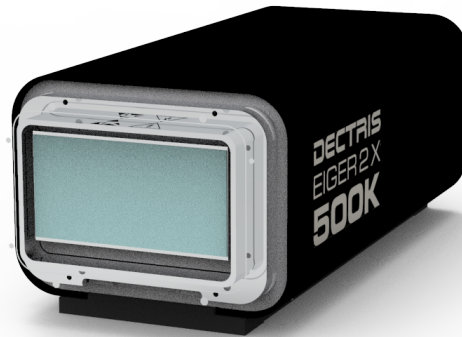

**Figure 5.1:** The EIGER2 X 500K-RW Detector without the cover and Mylar<sup>®</sup> frame in place (front view).

The Mylar window can be mounted or removed using 4 captive Allen screws (tool size I2)  
Do not exceed the maximum torque of 0,5 Nm when tightening the screws!

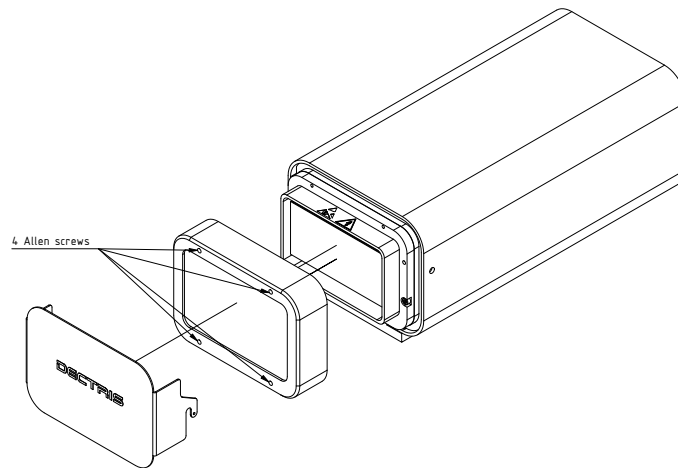

Project / Document type		Material / Surface	Weight	General tolerances	Format	Scale
			0.00 kg	ISO 2768 - mK	A3	1 : 2
State		Drawing number	Rev.	Created by	Approved by	
Freigegeben		MEC-006280	1	erb	gec	
<b>DECTRIS</b> DECTRIS Ltd, Tafelweg 1 5405 Baden-Daerfluh, Switzerland		Title			Date of issue	
		EIGER2 500K-RW Outline			17.03.2020	
We reserve all rights in connection with this document. Without our agreement it may be neither copied nor made accessible to a third party.		Comment / Item number			Sheet	
					2 / 2	

**Figure 5.2:** Location of the Allen screws for dismounting the Mylar®.

### 5.3. Mounting

Caution

#19



Do not place the detector and the power supply near heat sources or in a place subject to direct sunlight, excessive dust or mechanical shock.

Warning

#5



Do not use the power supply in vacuum.

Caution

#20



Make sure that the power supply has adequate ventilation.

- Do not cover any air intakes or outlets.
- Place the power supply in a location with adequate air circulation.
- Make sure the power supply has enough space for proper ventilation (minimum wall distance: 100mm).
- Do not operate the power supply in a closed environment.



The detector can be mounted in the ways which are described below.

### 5.3.1. Mounting from Below

Warning

#6



It is strictly forbidden to add any threads to the detector base plate or to the detector housing.

The detector should be mounted using the four internal M6x1 threads as shown in figure 5.3 (indicated with yellow circles).

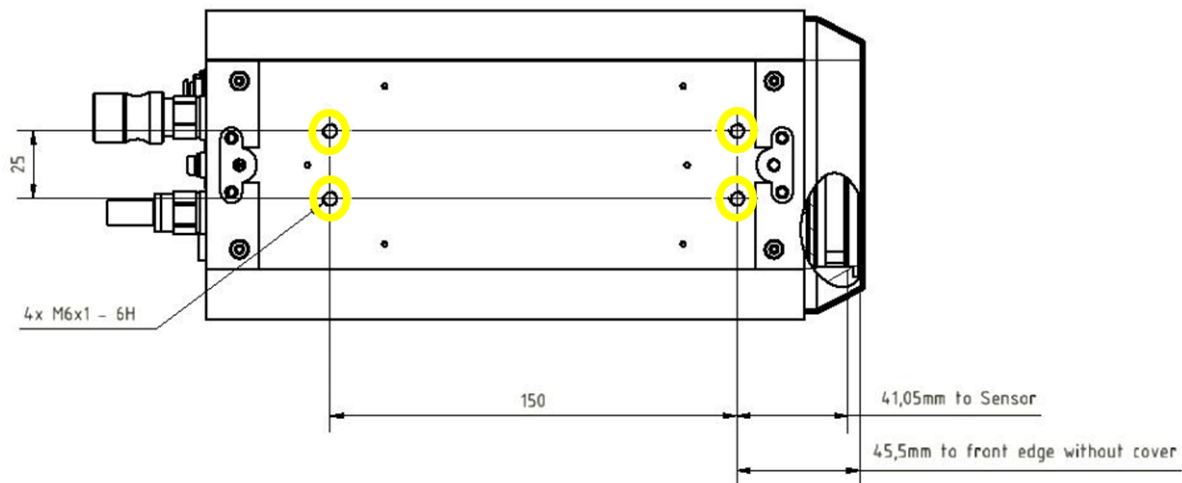

**Figure 5.3:** Drawing of the EIGER2 X 500K-RW Detector Base Plate (also printed separately in the user documentation folder)

Caution

#21



The four M6 screws must not intrude into the detector more than 10 mm.

### 5.3.2. Mounting from Above

Use the mounting brackets (optionally available) as depicted in figure 5.4. These mounting brackets have to be mounted on the base plate of the detector. The detector should be mounted using all four outer 7 mm holes (indicated with yellow circles).

Caution

#22



Make sure the mounting brackets are mounted and properly tightened using the screws provided. The placement of the screws is indicated with diamonds in figure 5.4.

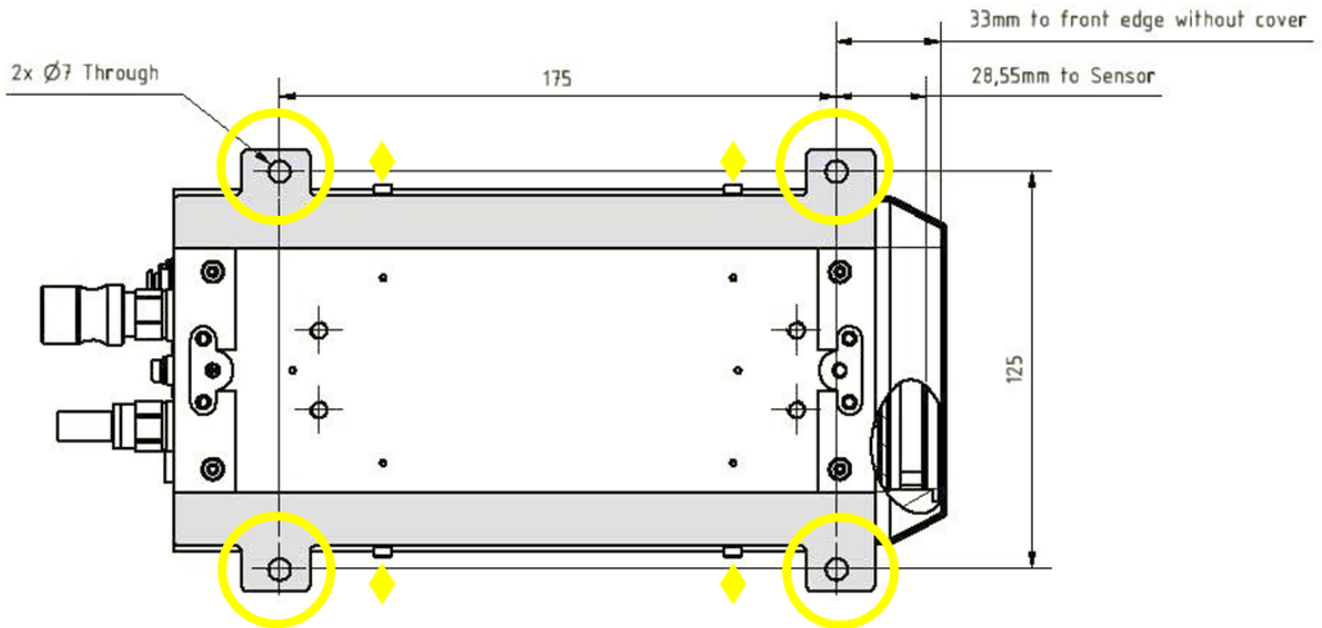

**Figure 5.4:** Drawing of the EIGER2 X 500K-RW Detector Base Plate with Mounting Brackets (bottom view)

## 5.4. Grounding of the Detector

Caution

#23



The mains plug of the power supply has to be connected to a grounded power outlet.

Although the detector might be already grounded via the mounting bolts, the detector should be grounded additionally via the functional ground connector at the back in order to establish a defined grounding.

## 5.5. Connection to Dry Air or Nitrogen

Warning

#7



When venting with nitrogen, take proper precaution against the risk of asphyxiation caused by oxygen displacement from nitrogen. Ensure sufficient ventilation and oxygen level monitoring. Use compressed air for venting large vessels or in confined spaces.

Caution

#24



Humidity might damage the detector. Make sure that the detector is operated within the allowed ambient conditions (see section 3.3).

The EIGER2 X 500K-RW detector has to be connected to a dry air (or nitrogen) source to avoid humidity and condensation damage when it is outside of the storage box. For information on system connections, refer to the section 4.1.5 and for storage of the detector system refer to the section 7.5.



Oil free, dry air of <20 % relative humidity or nitrogen must be used.

- The recommended flow is 5 L/h to 10 L/h (at 2 bar).
- For reliable operation we recommend dry air of <5 % relative humidity.
- The gas pressure must not exceed 2 bar.
- The minimum gas pressure is 1 bar.
- The humidity control shuts down the power of the detector modules when the humidity is too high (see chapter 6).

An external valve is supplied together with the system to regulate the dry air flow (see figure 5.5). Regulate the airflow according to the information above.



**Figure 5.5:** External dry air valve

### 5.5.1. In-Vacuum Use

#### Caution

#25



The temperature and humidity control cannot prevent condensation issues and resulting damage to the sensor due to improper use. Always make sure that the detector is warmed up (thermal stabilization unit temperature set to 23 °C) prior to pumping down, venting, and opening the chamber. Only use dry air or nitrogen for venting.

For in-vacuum operation no nitrogen or dry air flow is necessary. Refer to section 7.4 for more information.

## 5.6. Fiber Optic Cable Installation

The connection between the detector head and the detector control unit uses fiber optic cables in order to provide best connectivity during operation. However, special care has to be taken when installing the fiber optic cables. Fiber optic cables are sensitive to dirt on the connectors and excessive bending, squeezing, or pinching of the cables.

The EIGER2 X 500K-RW is delivered with a 30m long optical fiber cable. The connection to the detector consists of 2 x LC/UPC duplex fiber optic connectors.

Detectors used in vacuum need different optical cables. For information about vacuum cables, refer to the vacuum feedthrough set specifications or contact DECTRIS® support.

### 5.6.1. Installing the Cables

The fiber optic cables come with a pulling eye to make cable installation easier and a cable sock to protect the connectors. Use the pulling eye to pull the cable until its destination. Once the cable is properly installed, the cable sock can be removed.

The minimal bending radii are 10 × diameter for static and 20 × diameter for dynamic bends. The diameter of the fiber trunk is ca. 4.5 mm while the diameter of the 0.5 m long fiber breakout at both ends of the cables is ca. 3 mm. We therefore recommend avoiding both static and dynamic bending radii smaller than 10 cm – make sure not to exceed this bending radius during the course of the fiber cable installation. Use cable trays or similar to guide the cables and protect them. Stepping on the cables can damage the cables. Also make sure that there is no tension on the connectors.

### 5.6.2. Checking the Connection

The EIGER2 web interface offers a way to assess the quality of the connection between the detector control unit and the detector head. The User Manual explains how to access the web interface.

In order for the cable check to work properly, the detector has to be initialized first. The cable check shows the active connections and the transceiver Rx and Tx power. Rx values below 0.25 mW point towards a problem in the connection. Dirty connectors are the most likely reason for bad connections. Follow the instructions in section 5.6.3 in case of any issues with the connection.

### 5.6.3. Cleaning the Connectors

Dirty fiber connectors are the most common reason for bad connections. Any dirt or dust particle on the connector can lead to poor signal and may also lead to permanent fiber and/or connector damaged when plugged. We recommend to always clean the fiber optic connectors before connecting them. Make sure to clean both the connector and the transceiver modules, as both can be dirty.

It is recommended to first use dry cleaning technique like a fiber optic cable cleaning pen. These pens are easy to use for both the connectors and the transceivers. Fiber optic inspection microscopes can help assess if the optical fiber connectors are clean. If dry cleaning did not help, wet cleaning can be used. However, make sure to use wet cleaning kits designed specifically for fiber optic connectors and follow the manufacturers instructions.

Always cover the connectors and transceivers when they're unplugged. The cables and transceivers all come with covers which can be used for this.

## 5.7. Connection to Thermal Stabilization Unit

Caution

#26



- Use only the included thermal stabilization unit.
- Use only the supplied hose couplings.
- Do not add any component other than those supplied by DECTRIS® to the cooling circuit.

The EIGER2 X 500K-RW detector is water-cooled and must be connected to a dedicated thermal stabilization unit. The detector is supplied with quick coupling connectors to connect the cooling tubes to the thermal stabilization unit. Optional 90°-angled connectors can also be supplied.

Do not add any component other than those supplied by DECTRIS® to the cooling circuit. Using the wrong material in the cooling circuit leads to galvanic corrosion, which can permanently damage the detector. Contact DECTRIS® support at support@dectris.com in case the supplied components are not compatible with your setup.

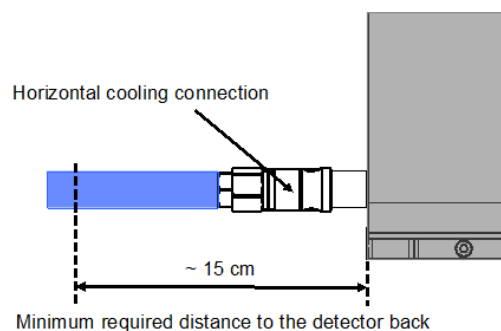

**Figure 5.6:** Horizontal coolant connectors

## 5.8. Mounting the Detector Control Unit

Caution

#27



Make sure that the detector control unit has adequate ventilation.

Caution

#28



The mains plug of the detector control unit has to be connected to a grounded power outlet.

The detector control unit can be mounted in a standard 19 inch rack, which has to be properly grounded.

## 6. TEMPERATURE AND HUMIDITY CONTROL

The EIGER2 X 500K-RW detector has a combined temperature and humidity sensor. The temperature and humidity control shuts down the detector when the humidity or the temperature of the sensor exceeds the following limits:

**Table 6.1:** Temperature and Humidity Limits

Shutdown Temperature		Shutdown Humidity
Lower Limit	Upper Limit	Upper Limit
< 15 °C	> 35 °C	> 40 % at operation / > 40 % at start-up

The communication with the detector control unit will remain active after a temperature shut down (only power of the modules shuts down).

### Warning

#8



The temperature and humidity control cannot prevent condensation issues and resulting damage to the sensor due to improper use. Always make sure that the detector is set to the correct temperature (thermal stabilization unit temperature set to 23 °C).

### Information

#10



The detector has an internal thermal protection switch. If the thermal protection switch is activated, it turns the detector off to prevent damage. In this case all LEDs will be off and no communication is possible any more with the detector. The detector will automatically power on again, as soon it is cooled down to appropriate working conditions.

### Information

#11



If the humidity is outside the specified range, the software will prevent operation. The user can check the temperature and humidity via the API, as long as the temperature is not out of range. If the temperature breaches safe conditions the thermal protection switch will be triggered and the detector will completely switch off.

To start the detector correctly, please refer to section 7.1 and execute the correct startup procedure.

Make sure that the cooling unit is running at the recommended temperature (according to section 4.3) and that Nitrogen or dry air flow is turned on at the recommended flow rate, given in section 5.5. Then restart the software.

### Information

#12



A free-flowing air stream is mandatory in order to properly cool the electronics inside the detector. Do not cover any ventilation holes.

## 7. OPERATION PROCEDURE

Before operating the detector, make sure you have read the Technical Specifications and the User Manual.

### 7.1. Getting Started

Before switching on:

- Mount the detector properly.
- Connect the detector to ground potential, using the functional ground connector.
- Connect the detector to power supply.
- Connect the detector to a nitrogen or dry air source, capable of supplying at least the minimum recommended flow rate.
- Connect the coolant hoses. Make sure they are properly mounted on both sides.
- Set the temperature to 23 °C on the thermal stabilization unit and turn it on. If the detector was not at room temperature, wait until the thermal stabilization unit has reached stable operation.
- Connect the power cable, the local network cable, and the detector data cable to the detector control unit. (If more than one data cable is required, please pay attention to the numbering of the cables as described in table 4.2)

### 7.2. Startup Procedure

Please use the following startup procedure:

- Turn ON the dry air or nitrogen at least 30 min before turning on the detector.
- Push the standby button at the back of the detector into its depressed position.
- Turn ON the detector control unit. Wait at least 5 min before trying to connect.

The detector is now ready to use.

Information

#13



The software start-up procedure is described in detail in the User Manual.

### 7.3. Turning Off the Detector

To turn off the detector:

- Press the standby button to bring the detector to the standby state.
- The detector power cable can now be disconnected if needed.
- Turn OFF the detector control unit.
- Do not remove the nitrogen/dry air connection. It is a requirement that it is left at the recommended flow rate according to section 5.5.

Warning

#9



As long as the detector power cable is connected, the detector has to be considered under power.

## 7.4. Vacuum Operation

DECTRIS® detectors can be provided for vacuum operation. The typical reachable vacuum is  $10^{-3}$  mbar (read-out electronics in vacuum) or  $10^{-6}$  mbar (only detector head in vacuum). The outgassing rate and content are not specified. The vacuum compatibility option guarantees that the detector will operate in the mentioned vacuum range. Detectors ordered with a vacuum compatibility option have been tested in vacuum.

To see if a detector is vacuum compatible, check whether the vacuum compatibility option is included in the order confirmation received from DECTRIS®.

### 7.4.1. Ambient Conditions for In-Vacuum Use

For in-vacuum operation of the detector following conditions must be fulfilled:

**Table 7.1:** In-Vacuum Operating Conditions

In-Vacuum Condition	Definition
Pressure during operation	The product of pressure and largest distance between any outside surface point of the detector and inside surface point of the vacuum chamber or any component within the chamber must not exceed 0.1 torr · cm or $1.3 \times 10^{-3}$ mbar · m
Detector mounting plate temperature during operation	10 °C to 25 °C
Thermal stabilization unit set temperature in vacuum	17 °C
Chamber temperature during "bake-out" (detector unpowered)	max. +60 °C (for temperatures > 40 °C make sure the thermal stabilization unit is set to +40 °C and running)

### 7.4.2. Operation Procedure In-Vacuum

Make sure the vacuum conditions in table 7.1 are met and follow below procedures for venting and pumping down the vacuum chamber.

Warning

#10



Prior to pumping down (and venting):  
Always make sure the detector has NO POWER and is WARMED UP to room temperature. Otherwise it could be damaged through electrical discharge or condensation.

### Pumping Down the Vacuum Chamber

- Mount the detector properly inside the vacuum chamber.
- Connect the detector power, data, trigger, and coolant lines inside and outside the vacuum chamber.
- Connect the detector control unit and the detector data cables.
- Make sure the standby button on the back of the detector is in its depressed state.
- Make sure the detector is POWERED OFF by disconnecting the power supply outside the vacuum chamber.
- Close the vacuum chamber and start to pump down.
- Once the pressure inside the vacuum chamber is below  $1 \times 10^{-2}$  mbar set the temperature on the thermal stabilization unit to 17 °C and turn on the thermal stabilization unit (pumping down a warm detector prevents condensation issues).
- After the thermal stabilization unit has reached the set value and the pressure inside the vacuum chamber is sufficiently low to meet the operating conditions, power up the detector.



## Venting the Vacuum Chamber

- Turn OFF the power to the detector, either by disconnecting the power supply outside the vacuum chamber or by switching OFF the detector power supply.
- Set the temperature to 23 °C on the thermal stabilization unit and let the detector warm up at least 30 min to prevent condensation inside the vacuum chamber.
- Use dry air or nitrogen to vent the chamber.

## 7.5. Storing the Detector

Information

#14



Even if the detector is not in operation, it is recommended that the dry air or nitrogen flow is maintained to reduce the risk of humidity damage to the detector.

Please follow these instructions:

- Put the detector in a plastic bag, add at least 200 g of drying agent (i.e. silica gel) into the bag and seal it air-tight.
- Check the humidity and change the drying agent frequently for compliance with the storage requirements in section 3.3.

## 7.6. Cleaning and Maintenance

Caution

#29



The Mylar<sup>®</sup> foil must not be touched or cleaned. If it is damaged, please contact DECTRIS<sup>®</sup> technical support.

The detector housing can be cleaned with a soft tissue. The EIGER2 X 500K-RW detector does not require any maintenance.

The coolant liquid has to be replaced every 12 months. For information on the coolant liquid, see section 4.3. Please refer to the user documentation of the thermal stabilization unit for more detailed information about the maintenance of your thermal stabilization unit.

## 8. TROUBLESHOOTING

Table 8.1 provides an overview of possible problems with the detector system and instructions in order to solve the problems. If the problem you are experiencing is not listed below or if the instructions do not help, please contact support@dectris.com.

The LEDs at the back of the detector can provide valuable information for troubleshooting. Check section 4.1.4 for further information.

**Table 8.1:** Troubleshooting

<b>Problem</b>	<b>Cause</b>	<b>Solution</b>
Detector control unit does not start properly.	Detector control unit is not powered.	Check the User Documentation of the detector control unit (see section 3.2.3).
Communication error, the detector is not found at startup.	Data cable is not connected or defective.	<p>Check the connection between detector control unit and detector. Make sure that there is a direct, peer-to-peer connection between the detector control unit and the detector. Check that all cables are properly inserted and the fiber connectors are clean.</p> <p>Avoid tangling or strong bending of the data cables.</p> <p>Check the status of the LINK LED. If the detector control unit and the detector are powered and correctly connected, the LINK LED should be green (Takes up to 30s after power up).</p>
Detector shuts down.	Temperature or humidity error.	<p>Check that the detector is properly supplied with coolant and check the temperature of the coolant at the front panel of the thermal stabilization unit.</p> <p>Check the flow of nitrogen or dry air.</p> <p>Check the temperature of the detector using the SIMPLON API and wait until the detector cools down.</p> <p>Restart the detector again.</p>
The detector fails to turn on.	The power cord is not connected or the plug is incompletely inserted.	Connect the power cord firmly. Check the LED on the external power supply.
	The temperature is over the critical limit. The thermal protection was triggered.	Check the thermal stabilization unit. The detector will power on again, as soon as the temperature is within the allowed operating conditions.
Image acquisition not possible.	Detector is not properly initialized.	Initialize the detector via the SIMPLON API. (See API Reference)

**Table 8.1:** Troubleshooting - continued

<b>Problem</b>	<b>Cause</b>	<b>Solution</b>
Detector housing is humid.	Ambient humidity around the detector exceeds the operating conditions.	Shut down the detector immediately and check the humidity. Power up the detector only when the ambient humidity has been reduced.

---

## TRADEMARKS AND PATENTS

### Trademarks

Registered trademarks®: "DECTRIS", "DECTRIS BERNINA", "DECTRIS CRISTALLINA", "DECTRIS EIGER", "DECTRIS ELA", "DECTRIS INSTANT RETRIGGER", "DECTRIS MYTHEN", "DECTRIS PILATUS", "DECTRIS QUADRO", "DECTRIS SANTIS", "DECTRIS SÄNTIS", "DECTRIS SINGLA", "DECTRIS TITLIS", "DETECTING THE FUTURE"

© 2/ 2023 DECTRIS Ltd., all rights reserved • Subject to technical modifications.